



Description

Tablet trolley with battery charging function is used to store and easily charge tablets. It works perfectly in schools, universities, libraries or conference rooms, i.e. wherever there is a need to safely store and simultaneously charge tablets. The contents of the cabinets are protected by a door equipped with a lock. Moving the trolley is possible thanks to the 4 swivel wheels. WNT trolleys can store and charge up to 32 tablets and 1 laptop at the same time. Safety during charging is ensured by a fuse and specialized electronic systems. Inserts made of non-flammable foam allow you to store tablets and protect them from damage. Perforation on the stroller housing ensures proper air circulation inside. The trolley is covered with an 18 mm chipboard top, available in 6 colors of veneer. Standard trolleys available in 16 RAL colors.

Description

WNT

- 5-year warranty (according to the warranty conditions for Malow products).
- Trolley made of 0.8 - 2 mm thick sheet metal.
- Trolleys adapted to fast charging of tablets thanks to USB sockets with a voltage of up to 12 V and a current of up to 3 A. A fuse is used for overload protection.
- Additional shelf (100x340x520mm) with 2 laptop charging sockets.
- The contents of the cabinets are protected by a door equipped with 2 points. lock. In addition, the perforation on the trolleys ensures proper air circulation inside the device.
- Rubber corners protecting the lower edges of the trolley.
- 4 swivel wheels, including 2 with a lock.
- Handles for easy movement. Holder for hanging the coiled power cord.
- Chipboard top available in 6 veneer colors as standard.



Proper operation is confirmed by the illuminated switch



Handles on both sides of the trolley make it easy to move



A lock with two keys secures the contents of the trolley



4 swivel wheels including 2 lockable for easy movement

TABLET CHARGING TROLLEY WNT Q and WNT QR

Options available

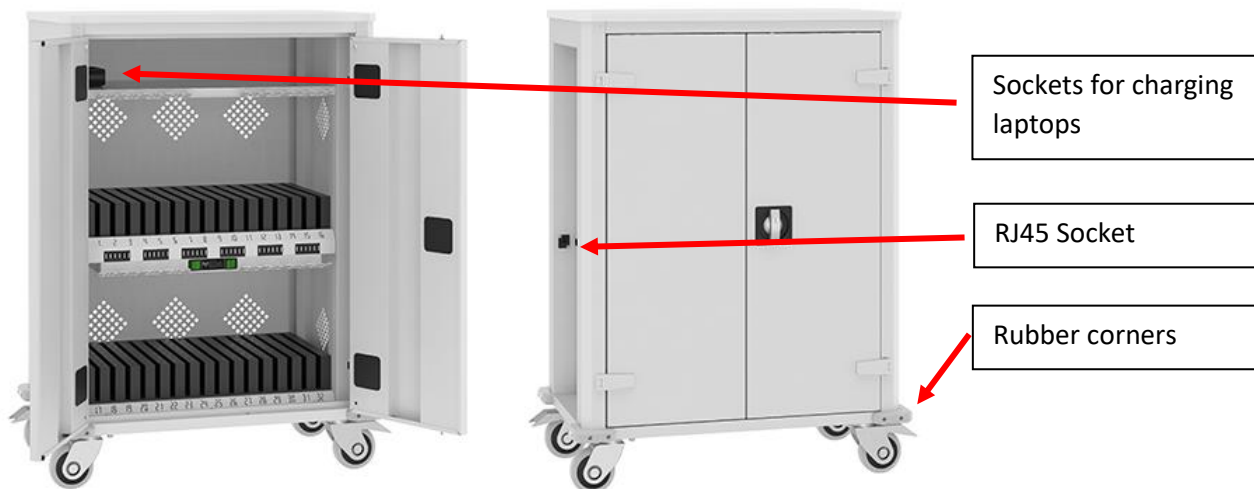

Designation	WNT 33 Q	WNT 33 QR
Code	WNL 0917050904	WNL 0917051304
H x W x D	1050 x 730 x 440 mm	
Number of compartments	32 tablets + 1 laptop	
Access point	-	The Access Point allows you to create a Wi-Fi network, which allows for easy and quick connection of devices. The socket on the side allows you to connect a local network to the Internet or a computer.

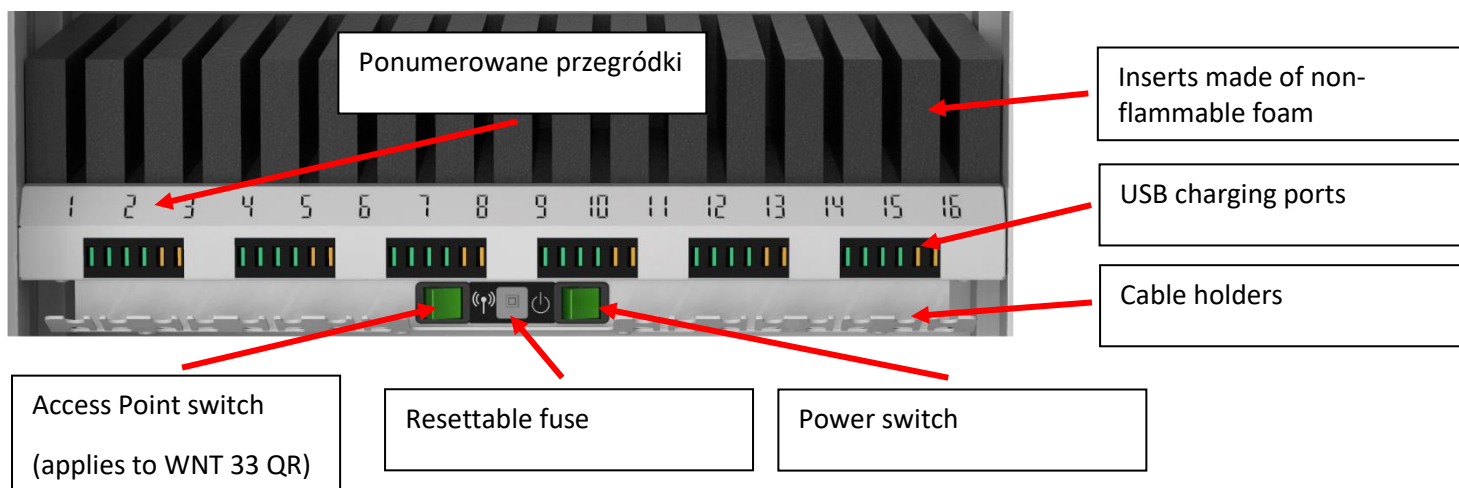

Marks description

- 5-year warranty shows that we are confident in our products due to high quality workmanship and reliability. We want you to feel safe and satisfied with working with us.
- ISO certification confirms compliance with standards and the high quality of products and services we offer.
- PZH approval is granted for a product that does not in any way adversely affect health or the environment.
- Zircon technology provides very good corrosion protection for our products. In addition, this process improves paint adhesion.
- We offer 16 RAL colours as standard. Thanks to this our furniture can be matched to any interior.
- We test our products in our own laboratory, the Centre for Research and Development (CBR).

* The graphics presented in the catalog are for illustrative purposes only